



# DRYING

## SINGLE POCKET DRYERS ECONOMIC LINE SC-11/14 M

### CHARACTERISTICS

#### M PROGRAMMER

- M programmer: push buttons to control temperature and time.

#### OUTSTANDING FEATURES

- Reversing drum action as standard.
- Frequency inverter as standard.
- Galvanized drum as standard.

#### EFFICIENCY

- Big fluff filter.

#### VERSATILITY

- Make to order - customisation.
- OPL > Multivending - Standard OPL model easily transformable to coin laundry uses.

#### ERGONOMICS

- Biggest door diameters.
- Opening sense of door adjustable on site.
- 180° opening hinges.

#### MAINTENANCE

- Hinged panel: easy and ergonomic access
- Technical menu: statistics for technicians.
- Easy to access to components.

#### OTHERS

- White painted panels.
- Anti-wrinkle at the end of the cycle.
- Heating options: electric, gas and steam.
- CE approved.

### OPTIONS

- Opposite door opening.
- Back panel external air + filter.
- Reduced power (12kw instead of 18kw) for electric heated SC-14 model.
- Maritime wooden packing.
- Other voltages available.
- Self-service payment systems.

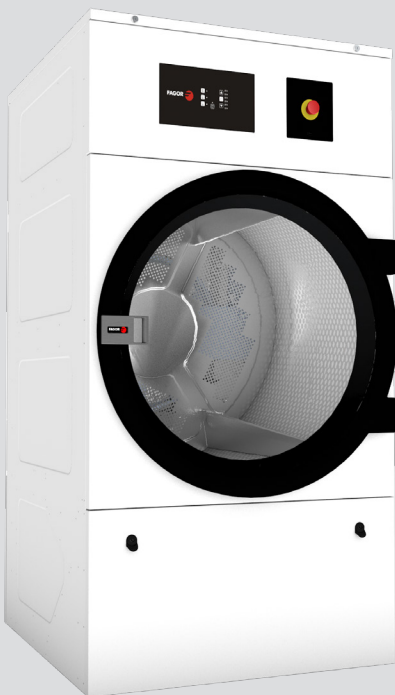

	U.	SC-11 M	SC-14 M
<b>CAPACITY</b>			
Capacity 1/18	Kg	11,7	15
	Lb	25,7	33,1
Capacity 1/20	Kg	10,5	13,5
	Lb	23,1	29,8
<b>DRUM</b>			
Ø Drum	mm	750	750
	inch	29,53	29,53
Drum length	mm	475	610
	inch	18,7	24,02
Drum volume	l	210	270
	cu ft	7,41	9,53
Ø Door	mm	574	574
	inch	22,6	22,6
Floor to door center	mm	976	976
	inch	38,43	38,43
Floor to lower part of the door	mm	618	689
	inch	24,33	27,13
Drum motor power	kW	0,37	0,37
<b>ELECTRIC POWER</b>			
Installed heating power	kW	12	18
Installed electrical power	kW	12,97	18,97
Evaporation capacity	l/h	9,3	13,5
	USgallon/h	2,46	3,6
Hourly output	Kg/h	20,3	26,9
	Lb/h	44,8	59,3
<b>GAS POWER</b>			
Installed heating power gas	Kcal/h	17638	17638
	Btu/h	70000	70000
Installed heating power gas	kW	20,51	20,51
Installed electrical power	kW	0,67	0,67
Instant propane gas consumption (G31)	Kg/h	1,76	1,76
	Lb/h	3,88	3,88
Instant natural gas consumption (G20)	m³/h	2,17	2,17
	cfm	1,28	1,28
Evaporation capacity	l/h	14,5	15,4
	USgallon/h	3,83	4,068
Hourly output	Kg/h	28,6	30,3
	Lb/h	63,1	66,7
Ø Gas inlet	BSPP ISO 228-1	1/2"	1/2"
<b>STEAM POWER</b>			
Installed heating power steam	kW	30	30
	Btu/h	102364	102364
Installed electrical power	kW	0,67	0,67
Steam consumption (8 barG) - Stándar	Kg/h	53	53
Steam consumption (116 psiG)	Lb/h	63,8	63,8
Steam pressure - Standard	barG	6 - 9	6 - 9
	psiG	87 - 130.5	87 - 130.5
Steam inlet - steam outlet - Standard	BSPT- ISO7.1	3/4"	3/4"
Steam inlet - condensate outlet	NPT ANSI B1.20.1 Tapered	3/4"	3/4"
Steam consumption (5 bagG) - Low pressure	Kg/h	57	57
Steam consumption (72,5 psiG) - Low pressure	Lb/h	68,7	68,7
Steam pressure - Low Pressure	barG	3 - 6	3 - 6
	psiG	43.5 - 87	43.5 - 89
Steam Inlet - Steam Outlet - Low Pressure	BSPT - ISO7.1	1"	1"

VENTILATION					
Nominal air flow	m³/h	850	850		
	cfm	500,29	500,29		
Air outlet Ø	mm	200	200		
	inch	7,87	7,87		
Fan motor power	kW	0,25	0,25		
HEAT DISSIPATION					
Total max heat dissipation	kW	1,2	1,8		
	Btu/h	4097	6145,5		
Front pannel max heat dissipation	kW	0,84	1,26		
	Btu/h	2867,9	4301,8		
CONNECTIONS					
		ELECTRICAL	STEAM / GAS	ELECTRICAL	STEAM / GAS
Tension 230V - I + N + T	Nº x mm2 / A	3 x 25 / 63 A	3 x 1,5 / 16 A	-	3x1,5 / 16 A
Tension 230V - III + T	Nº x mm2 / A	4 x 10 / 40 A	3 x 1,5 / 16 A	4x16 / 63 A	3x1,5 / 16 A
Tension 400V - III + N + T	Nº x mm2 / A	5 x 4 / 25 A	3 x 1,5 / 16 A	5x10 / 32 A	3x1,5 / 16 A
DIMENSIONS / PACKING DIMENSIONS					
Net width / Gross width	mm	785 / 865	785 / 865		
	inch	30,91 / 34,06	30,91 / 34,06		
Net depth / Gross depth	mm	855 / 940	989 / 1.074		
	inch	33,66 / 37,01	38,94 / 42,28		
Net height / Gross height	mm	1.694 / 1.840	1.694 / 1.840		
	inch	66,69 / 72,44	66,69 / 72,44		
Net weight / Gross weight	Kg	172 / 180	180 / 190		
	Lb	379,2 / 396,83	396,83 / 418,88		
OTHERS					
Sound level	dB	64	64		

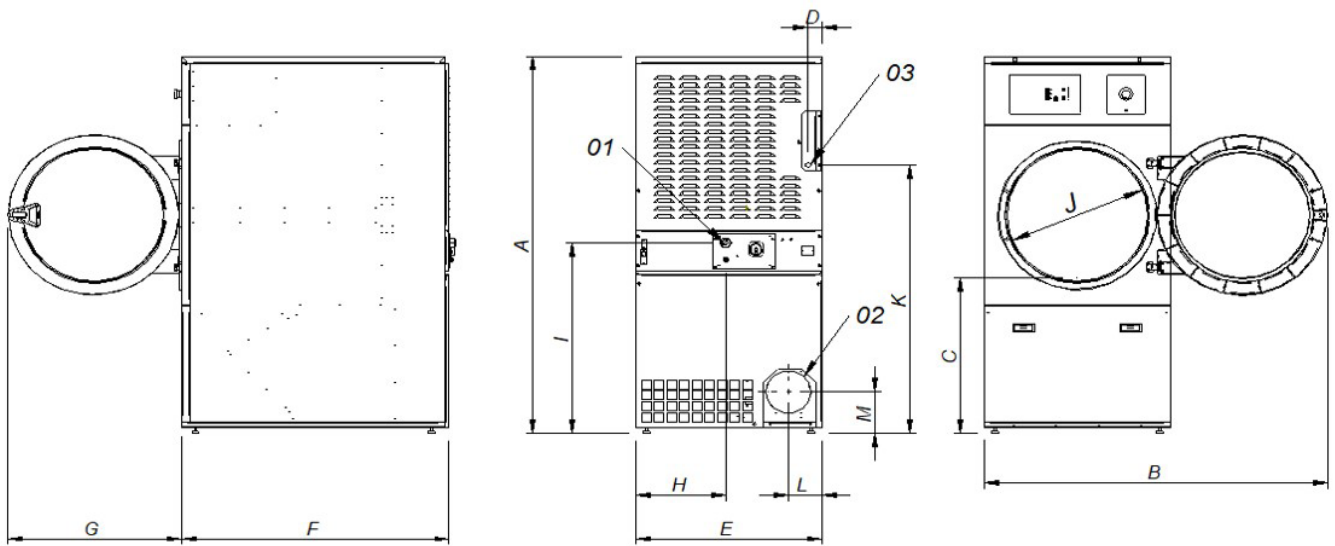

- 01. Power supply
- 02. Fumes output Ø200
- 03. Gas inlet 1/2"

	A	B	C	D	E	F	G	H	I	J	K	L	M	N	O
SC-11 M	1694	1447	689	68	785	855	735	380	870	575	1226	133	180	35	805
SC-14 M	1694	1447	689	68	785	989	735	380	870	575	1226	133	180	35	805



# DRYING

## SINGLE POCKET DRYERS ECONOMIC LINE SC-18/22 M

### CHARACTERISTICS

#### M PROGRAMMER

- M programmer: push buttons to control temperature and time.

#### OUTSTANDING FEATURES

- Reversing drum action as standard.
- Frequency inverter as standard.
- Galvanized drum as standard.

#### EFFICIENCY

- Big fluff filter.

#### VERSATILITY

- Make to order - customisation.
- OPL > Multivending - Standard OPL model easily transformable to coin laundry uses.

#### ERGONOMICS

- Biggest door diameters.
- Opening sense of door adjustable on site.
- 180° opening hinges.

#### MAINTENANCE

- Hinged panel: easy and ergonomic access
- Technical menu: statistics for technicians.
- Easy to access to components.

#### OTHERS

- White painted panels.
- Anti-wrinkle at the end of the cycle.
- Heating options: electric, gas and steam.
- CE approved.

### OPTIONS

- Opposite door opening.
- Back panel external air + filter.
- Reduced power (12kw instead of 18kw) for electric heated SC-18 model.
- Maritime wooden packing.
- Other voltages available.
- Self-service payment systems.

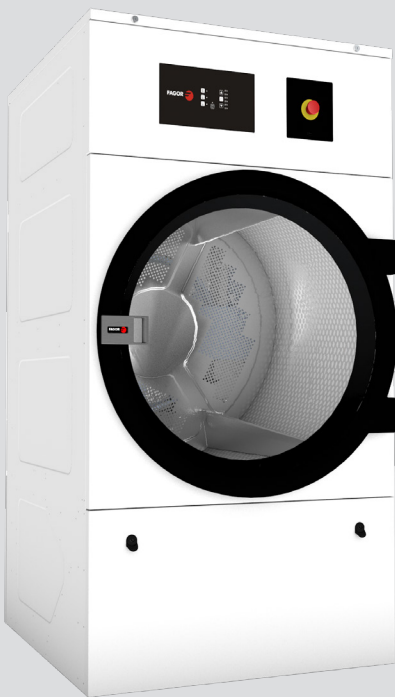

	U.	SC-18 M	SC-22 M
<b>CAPACITY</b>			
Capacity 1/18	Kg	18,3	24,3
	Lb	40,4	53,9
Capacity 1/20	Kg	16,5	22
	Lb	36,3	48,5
<b>DRUM</b>			
Ø Drum	mm	750	835
	inch	29,53	32,87
Drum length	mm	746	800
	inch	29,37	31,5
Drum volume	l	330	440
	cu ft	11,64	15,54
Ø Door	mm	574	574
	inch	22,6	22,6
Floor to door center	mm	976	1.030
	inch	38,43	40,55
Floor to lower part of the door	mm	618	672
	inch	24,33	26,46
Drum motor power	kW	0,37	0,37
<b>ELECTRIC POWER</b>			
Installed heating power	kW	18	24
Installed electrical power	kW	18,97	24,97
Evaporation capacity	l/h	14,10	17
	USgallon/h	3,72	4,5
Hourly output	Kg/h	28,3	34
	Lb/h	62,4	75
<b>GAS POWER</b>			
Installed heating power gas	Kcal/h	17638	26655
	Btu/h	70000	105775,6
Installed heating power gas	kW	20,51	31
Installed electrical power	kW	0,67	0,97
Instant propane gas consumption (G31)	Kg/h	1,76	2,66
	Lb/h	3,88	5,86
Instant natural gas consumption (G20)	m³/h	2,17	3,28
	cfm	1,28	1,93
Evaporation capacity	l/h	16,3	20
	USgallon/h	4,306	5,283
Hourly output	Kg/h	31,9	40
	Lb/h	70,3	88,2
Ø Gas inlet	BSPP ISO 228-1	1/2"	1/2"
<b>STEAM POWER</b>			
Installed heating power steam	kW	30	49,2
	Btu/h	102364	167877
Installed electrical power	kW	0,67	0,97
Steam consumption (8 barG) - Stándar	Kg/h	53	87
Steam consumption (116 psiG)	Lb/h	63,8	104,8
Steam pressure - Standard	barG	6 - 9	6 - 9
	psiG	87 - 130.5	87 - 130.5
Steam inlet - steam outlet - Standard	BSPT- ISO7.1	3/4"	1"
Steam inlet - condensate outlet	NPT ANSI B1.20.1 Tapered	3/4"	1"
Steam consumption (5 bagG) - Low pressure	Kg/h	57	-
Steam consumption (72,5 psiG) - Low pressure	Lb/h	68,7	-
Steam pressure - Low Pressure	barG	3 - 6	3 - 6
	psiG	43.5 - 91	43.5 - 93
Steam Inlet - Steam Outlet - Low Pressure	BSPT - ISO7.1	1"	1"

VENTILATION					
Nominal air flow	m³/h	850	1.200		
	cfm	500,29	706,29		
Air outlet Ø	mm	200	200		
	inch	7,87	7,87		
Fan motor power	kW	0,25	0,55		
HEAT DISSIPATION					
Total max heat dissipation	kW	1,8	2,4		
	Btu/h	6145,5	8193,9		
Front pannel max heat dissipation	kW	1,26	1,68		
	Btu/h	4301,8	5735,8		
CONNECTIONS					
Tension 230V - I + N + T	Nº x mm2 / A	-	3x1.5 / 16 A	-	3x1.5 / 16 A
Tension 230V - III + T	Nº x mm2 / A	4 x 16 / 63 A	3x1.5 / 16 A	4 x 25 / 80 A	3x1.5 / 16 A
Tension 400V - III + N + T	Nº x mm2 / A	5x10 / 32 A	3x1.5 / 16 A	5 x 10 / 40 A	3x1.5 / 16 A
DIMENSIONS / PACKING DIMENSIONS					
Net width / Gross width	mm	785 / 865	890 / 970		
	inch	30,91 / 34,06	35,04 / 38,19		
Net depth / Gross depth	mm	1.125 / 1.210	1.255 / 1.345		
	inch	44,29 / 47,64	49,41 / 52,95		
Net height / Gross height	mm	1.694 / 1.840	1.812 / 1.940		
	inch	66,69 / 72,44	71,34 / 76,38		
Net weight / Gross weight	Kg	187 / 200	210 / 230		
	Lb	412,26 / 440,92	462,97 / 507,06		
OTHERS					
Sound level	dB	64	65		

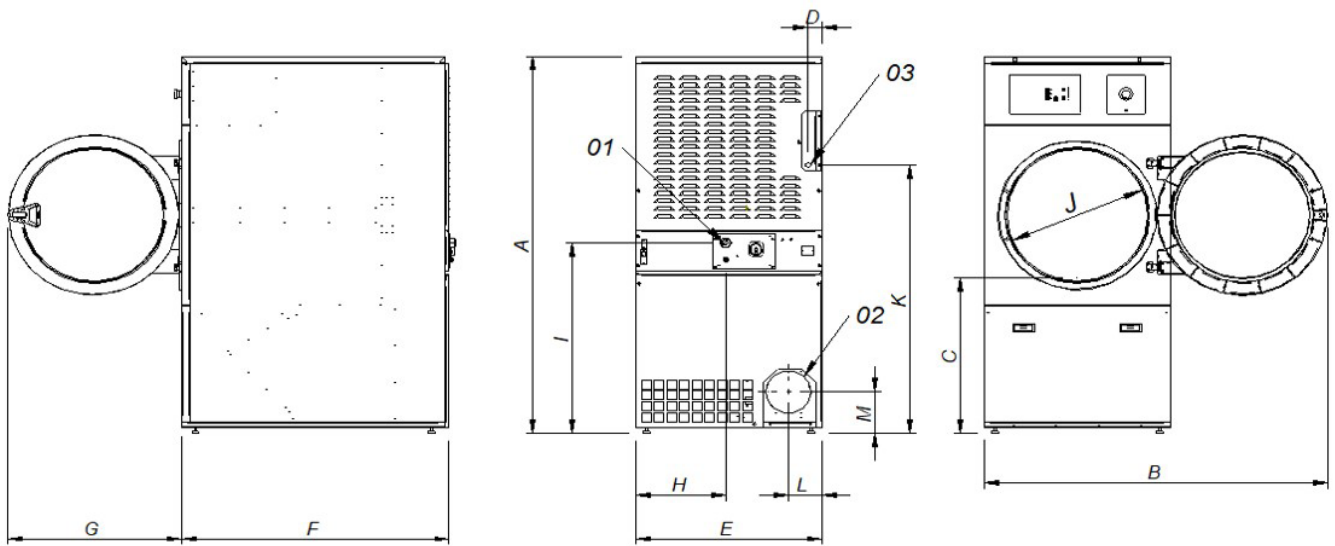

- 01. Power supply
- 02. Fumes output Ø200
- 03. Gas inlet 1/2"

	A	B	C	D	E	F	G	H	I	J	K	L	M	N	O
SC-18 M	1694	1447	689	68	785	1125	735	380	870	575	1226	133	180	35	805
SC-22 M	1812	1552	743	112	890	1255	735	107	920	575	1344	238	180	37	860



# DRYING

## SINGLE POCKET DRYERS ECONOMIC LINE SC-28/35 M

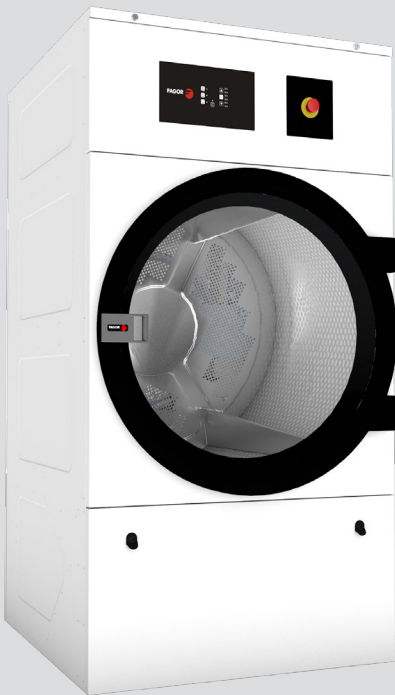

### CHARACTERISTICS

#### M PROGRAMMER

- M programmer: push buttons to control temperature and time.

#### OUTSTANDING FEATURES

- Reversing drum action as standard.
- Frequency inverter as standard.
- Galvanized drum as standard.

#### EFFICIENCY

- Big fluff filter.

#### VERSATILITY

- Make to order - customisation.
- OPL > Multivending - Standard OPL model easily transformable to coin laundry uses.

#### ERGONOMICS

- Biggest door diameters.
- Opening sense of door adjustable on site.
- 180° opening hinges.

#### MAINTENANCE

- Hinged panel: easy and ergonomic access.
- Technical menu: statistics for technicians.
- Easy to access to components.

#### OTHERS

- White painted panels.
- COOL DOWN - anti-wrinkle at the end of the cycle.
- Heating options: electric, gas and steam.
- CE approved.

### OPTIONS

- Opposite door opening.
- Back panel external air + filter.
- Maritime wooden packing.
- Other voltages available.
- Self-service payment systems.

	U.	SC-28 M	SC-35 M
<b>CAPACITY</b>			
Capacity 1/18	Kg	30,6	36,7
	Lb	67,3	80,8
Capacity 1/20	Kg	27,5	33
	Lb	60,6	72,8
<b>DRUM</b>			
Ø Drum	mm	947	947
	inch	37,28	37,28
Drum length	mm	780	936
	inch	30,71	36,85
Drum volume	l	550	660
	cu ft	19,42	23,3
Ø Door	mm	802	802
	inch	31,57	31,57
Floor to door center	mm	1.040	1.040
	inch	40,94	40,94
Floor to lower part of the door	mm	578	578
	inch	22,74	22,74
Drum motor power	kW	0,55	0,55
<b>ELECTRIC POWER</b>			
Installed heating power	kW	30	36
Installed electrical power	kW	31,15	37,15
Evaporation capacity	l/h	26,1	31,1
	USgallon/h	6,9	8,2
Hourly output	Kg/h	48,4	60
	Lb/h	106,7	132,3
<b>GAS POWER</b>			
Installed heating power gas	Kcal/h	35276	35276
	Btu/h	139986,5	139986,5
Installed heating power gas	kW	41	41
Installed electrical power	kW	1,15	1,15
Instant propane gas consumption (G31)	Kg/h	3,51	3,51
	Lb/h	7,74	7,74
Instant natural gas consumption (G20)	m³/h	4,34	4,34
	cfm	2,55	2,55
Evaporation capacity	l/h	30,9	32,1
	USgallon/h	8,163	8,480
Hourly output	Kg/h	59,3	63,9
	Lb/h	130,7	140,9
Ø Gas inlet	BSPP ISO 228-1	1/2"	1/2"
<b>STEAM POWER</b>			
Installed heating power steam	kW	50,1	50,1
	Btu/h	170948	170948
Installed electrical power	kW	1,15	1,15
Steam consumption (8 barG) - Stándar	Kg/h	89	89
Steam consumption (116 psiG)	Lb/h	107,2	107,2
Steam pressure - Standard	barG	6 - 9	6 - 9
	psiG	87 - 130.5	87 - 130.5
Steam inlet - steam outlet - Standard	BSPT- ISO7.1	1"	1"
Steam inlet - condensate outlet	NPT ANSI B1.20.1 Tapered	1"	1"
Steam consumption (5 bagG) - Low pressure	Kg/h	93	93
Steam consumption (72,5 psiG) - Low pressure	Lb/h	112	112
Steam pressure - Low Pressure	barG	3 - 6	3 - 6
	psiG	43.5 - 95	43.5 - 97
Steam Inlet - Steam Outlet - Low Pressure	BSPT - ISO7.1	1 1/2"	1 1/2"



VENTILATION					
Nominal air flow	m <sup>3</sup> /h		1.200		1.200
	cfm		706,29		706,29
Air outlet Ø	mm		200		200
	inch		7,87		7,87
Fan motor power	kW		0,55		0,55
HEAT DISSIPATION					
Total max heat dissipation	kW		3		3,6
	Btu/h		10242,4		12290,9
Front pannel max heat dissipation	kW		2,1		2,52
	Btu/h		7169,7		8603,6
CONNECTIONS					
		ELECTRICAL	STEAM / GAS	ELECTRICAL	STEAM / GAS
Tension 230V - I + N + T	N° x mm2 / A	-	3x1.5 / 16 A	-	3x1.5 / 16 A
Tension 230V - III + T	N° x mm2 / A	4 x 35 / 100 A	3x1.5 / 16 A	4 x 50 / 125 A	3x1.5 / 16 A
Tension 400V - III + N + T	N° x mm2 / A	5 x 16 / 63 A	3x1.5 / 16 A	5 x 16 / 63 A	3x1.5 / 16 A
DIMENSIONS / PACKING DIMENSIONS					
Net width / Gross width	mm		985 / 1.065		985 / 1065
	inch		38,78 / 41,93		38,78 / 41,93
Net depth / Gross depth	mm		1.054 / 1.154		1.210 / 1.310
	inch		41,5 / 45,43		47,64 / 51,57
Net height / Gross height	mm		1.975 / 2.080		1.975 / 2.080
	inch		77,76 / 81,89		77,76 / 81,89
Net weight / Gross weight	Kg		77,76 / 81,89		260 / 285
	Lb		230 / 260		573,20 / 628,32
OTHERS					
Sound level	dB		65		65

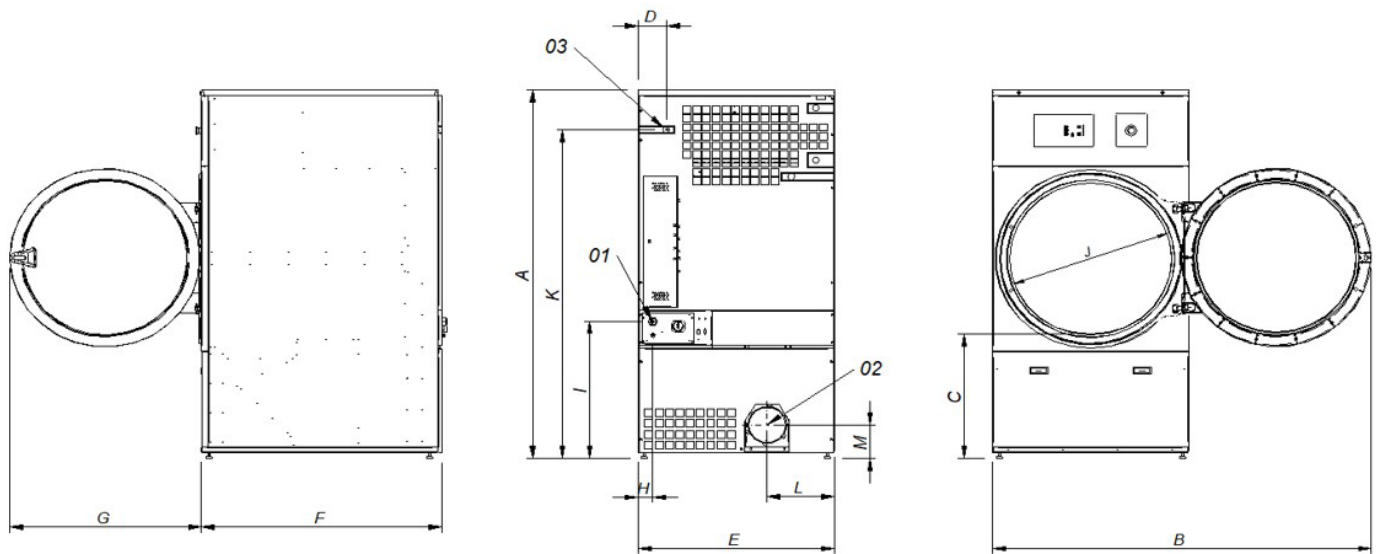

- 01. Power supply
- 02. Fumes output Ø200
- 03. Gas inlet 1/2"

	A	B	C	D	E	F	G	H	I	J	K	L	M
SC-28 M	1975	1910	660	141	985	1054	970	70	730	802	1768	337	178
SC-35 M	1975	1910	660	141	985	1210	970	70	730	802	1768	337	178